

# Product Operation Manual

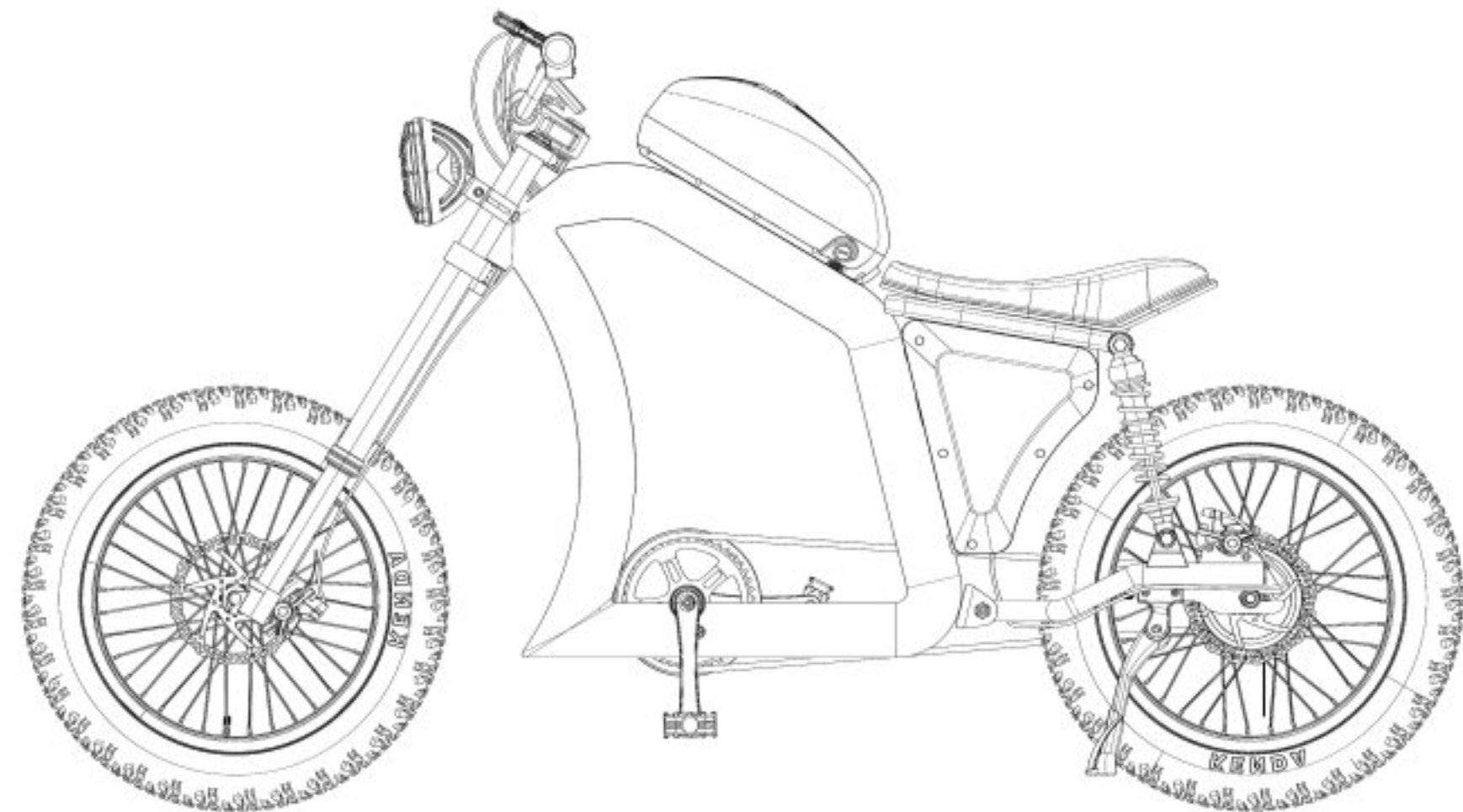

## MODEL: FT-02

Please read this manual carefully! This product operation manual contains safety precautions for the vehicle!

Please do not use an Mangosteen product without fully understanding its performance!

Please keep this product operation manual properly!

## Table of Contents

1. Product Overview.....	02
2. Notes for Safe Riding.....	03
3. Description of Components.....	04
4. Battery and Charger.....	05
5. Troubleshooting.....	09
6. Precautions for battery extraction .....	11
7. Maintenance and Servicing.....	12
8. Basic Parameters.....	14
9. After-sales Service .....	16

## 1 Product Overview

Thank you for purchasing Mangosteen product, hereinafter referred to as MGSD.

Please read this manual carefully before riding and keep it properly. Do not ride directly until the performance of MGSD is known. Please read the important safety items in this manual carefully. During riding, please abide by the local laws and regulations and ride safely.

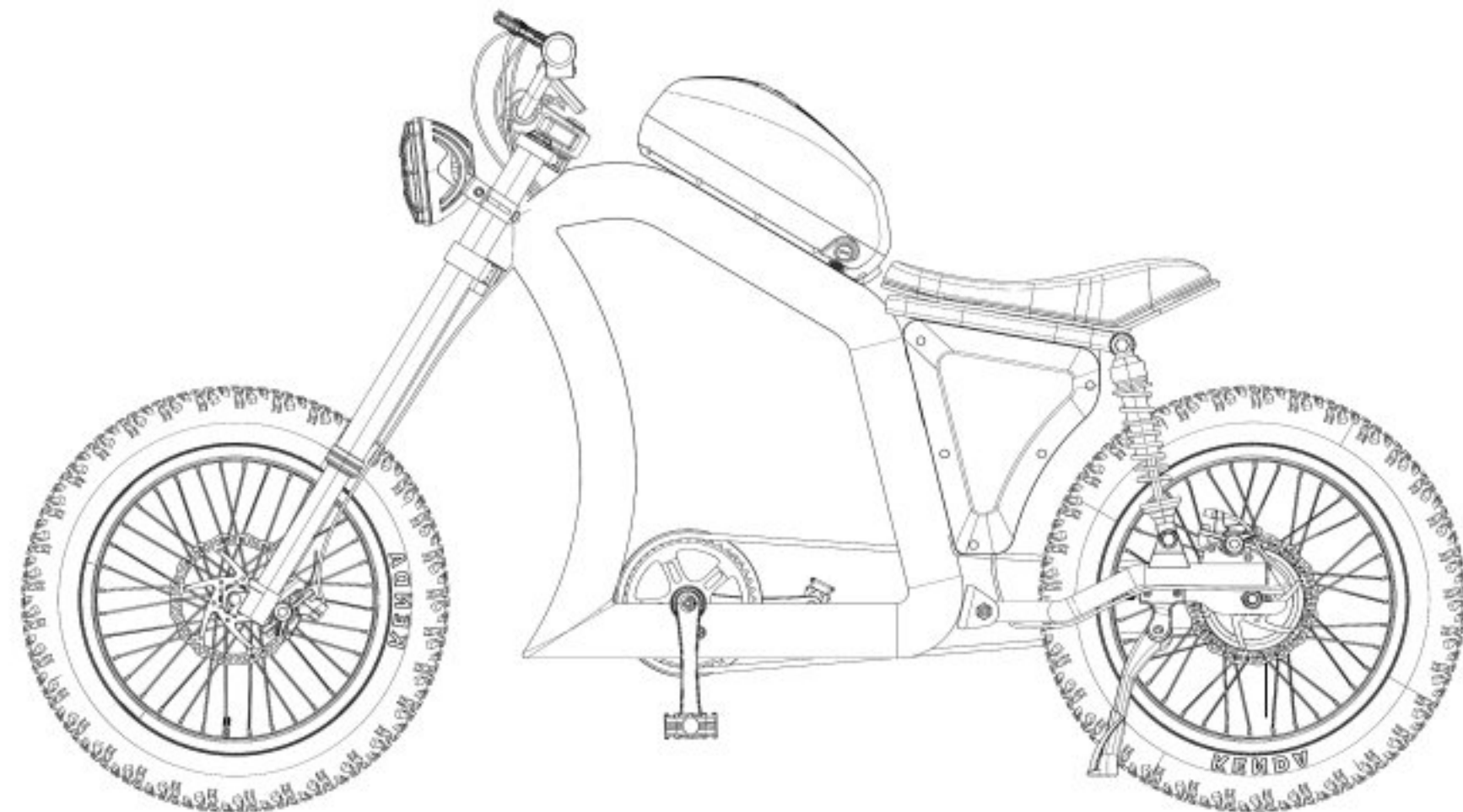

## 2 Notes for Safe Riding

- Please read this product operation manual carefully. Please do not use an electric two-wheeled vehicle without fully understanding its performance.
- Please obey the traffic laws and regulations. Don't go in a direction not allowed by traffic regulations, run a red light, etc. Don't use your mobile phone while riding.
- Please do not use the third-party accessories or disassemble, crack or modify without permission. The loss caused by this will be borne by you and you will lose our warranty commitment.
- As the product is constantly improved, the vehicle you purchased may be slightly different from the one in this manual. Please refer to the actual vehicle. If you have any questions about the usage, repair and installation of the vehicle, please contact our dealer or after-sales service center.

### △For the safety of you and others, please read the following carefully:

Riders shall abide by traffic laws and regulations and take care to ride safely

- Before riding, please carefully read the Product Operation Manual and check whether all parts and components are in good condition to ensure your riding safety. If any problem is found, please contact the dealer or after-sales service center in a timely manner.
- To ensure your safety, please wear safety helmet, gloves and other protective equipment during riding. Please do not wear loose clothing, as it will make you uncomfortable and unsafe while riding.
- You should be in good health and not tired so that you can control the vehicle in good condition. Riding is prohibited after taking drugs or drinking alcohol.
- This vehicle is not restricted under the rain and snow weather, but cannot excessively wade through the water. Wading through the water forcibly when the water level exceeds 10 cm depth may cause short circuit of electrical components and circuits of the vehicle, please be sure to pay attention!
- Please observe the traffic laws and regulations. Please slow down in rain, snow and slippery areas. Please increase the braking distance when braking so as to ensure safety.
- Please do not disassemble the parts and components by yourself.

Riders shall abide by traffic laws and regulations and take care to ride safely

- Do not park electric vehicle in building foyers, evacuation stairs, walkways and emergency exits;
- Do not charge and park the electric vehicle in the residential building. When charging, the electric vehicle shall be far away from combustibles, and charging time shall not be too long.

### 3 Description of Components

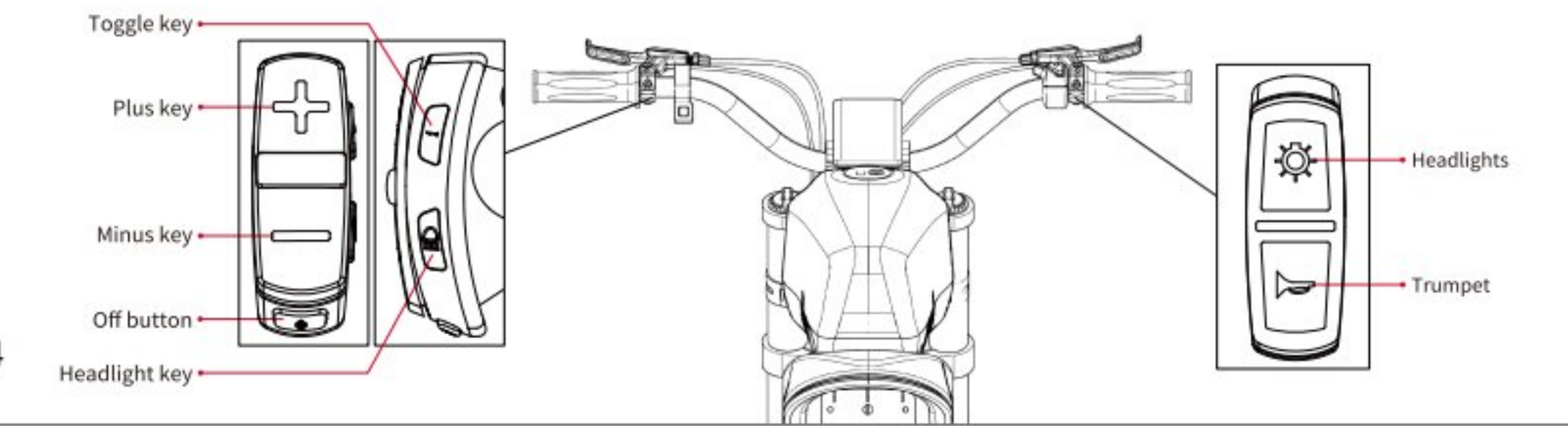
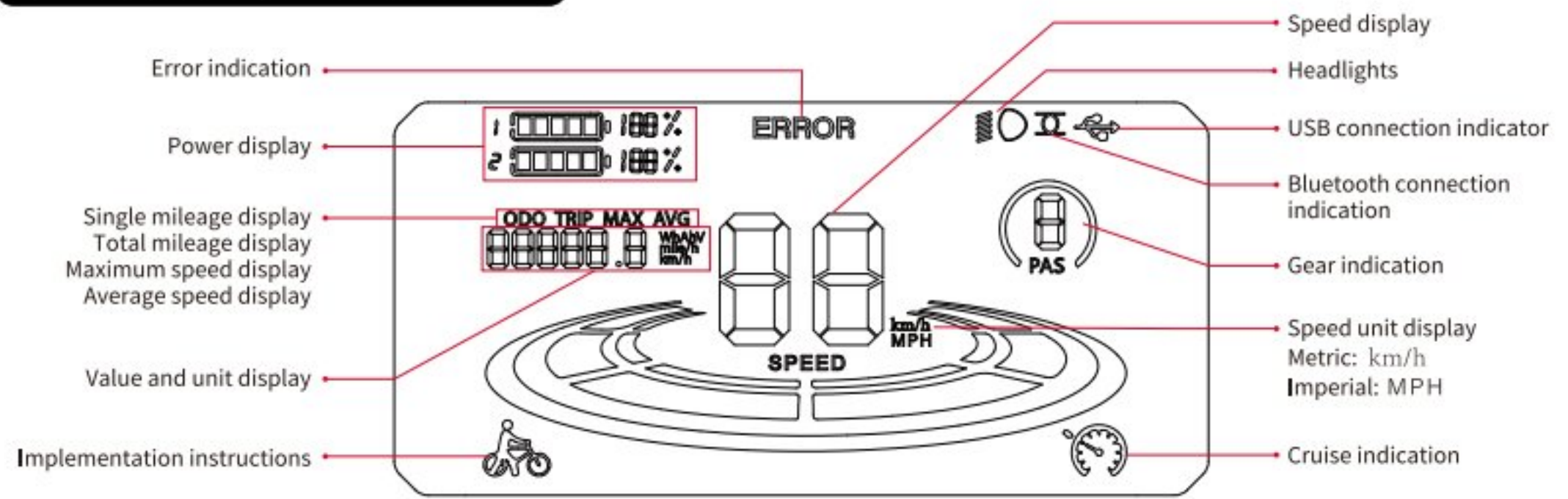

### 4 Battery and Charger

#### Battery operation instructions

The vehicle will provide you with two ways of battery charging and body charging for you to choose.

#### External charging mode

Take out the battery and insert the charging plug of the charger into the battery charging port for external charging. At this point, the battery's electric quantity indicator light will light up.

#### Vehicle charging mode

Put the battery into the battery holder, connect the power plug to the battery, and then insert the charging plug of the charger into the vehicle body charging port in the seat cask to charge the whole vehicle.

#### Description of the battery's electric quantity indicator light

In the charging state, it displays how much electric quantity the battery has. When the vehicle is fully charged, all the indicator lights will stay on and no longer blink.

In the non-charging state, if you press the electric quantity display key:

- Under normal conditions, the indicator light will display the electric quantity in the battery.
- If the electric quantity in the battery is less than 20%, a section of indicator light will flash to remind you to charge.
- When the vehicle is fully charged, the charger will appear green, indicating that it has been fully charged.

Detail:

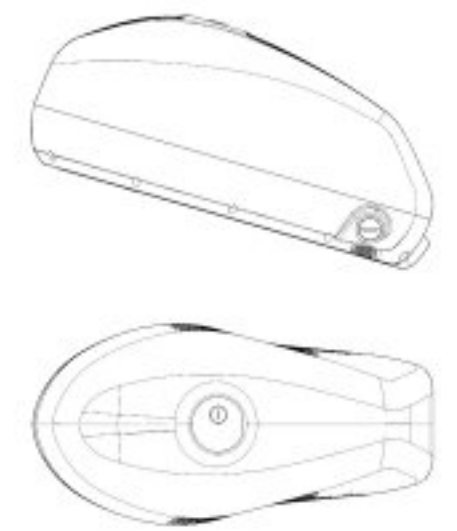

## Instructions before battery use

- Before use, please confirm that the battery is the original battery of the whole vehicle. Please do not use batteries of other brands or other models at will.  
Check whether the appearance of the battery is in good condition and ensure that there is no damage, leakage, heat generation, water immersion, smoke and other obvious phenomena.  
In order to ensure the safety of transportation, the battery's ex-factory electric quantity is about 30%. It is a normal phenomenon that there is low or no electric quantity when it is used for the first time due to the electric quantity consumption factors such as transportation and storage period. Please do not worry and just charge it according to the charging instructions.

The used batteries shall not be disassembled without authorization and shall be returned to the relevant professional departments for recycling and disposal.

### Use environment



Please use the battery at  
-10°C-45°C



Please keep the battery from  
getting wet with water, beverages  
and corrosive liquids



Please keep the battery away  
from heat source, open fire, flammable  
and explosive gas (liquid)



Please prevent metal foreign  
matters from entering the battery  
compartment

At low temperature, the available capacity of the battery will experience attenuation to different degrees. specific reference degrees are as follows: The available capacity is 70% at -10°C, 85% at 0°C, and 100% at 25°C. If you find that the battery smells, heats up, distorts and has other abnormal conditions, please stop using it immediately, stay away from the battery and contact the after-sales department.

A Battery is not a part that can be repaired by users. If there is any abnormal phenomenon, please contact the after-sales department for maintenance. Users who disassemble the battery without permission will not enjoy the policy of "three guarantees", and unauthorized disassembly may cause the battery to produce heat, smoke, fire or explosion.

## Charging environment



Please use the original charger matching with  
the battery for charging, and do not use a  
charger of other brands or models for charging.



Please charge the battery at an ambient  
temperature of 0°C-35°C.



Do not charge for more than 12 hours, so as not  
to affect the battery life.

- In the early stage of charging, the electric quantity will rise quickly, but in the later stage, it will rise slowly, which is the procedure set for charging safety and is a normal phenomenon.
- During charging in winter, when the outdoor temperature is low and the environment is below 0P, the battery charging will stop, which is a normal phenomenon. Please place the battery at an appropriate ambient temperature for charging to ensure the charging effect.
- During the charging process, some aluminum case chargers have temperature rise effect and higher surface temperature, which is normal. Please feel free to use. Please be careful to avoid the touch of children.

### Notes for charger use

- The charger can only be used indoors.
- Charging in confined space or under hot sun or high temperature is strictly prohibited; do not put the charger in the seat cask or tail box for charging.
- When charging, you should first plug in the battery, then add the power supply; when the vehicle is fully charged, you should cut off the power supply first and then unplug the battery.
- When the green light is on, the power shall be cut off in time. Do not connect the charger to the AC power without load for a long time without charging.
- During the charging process, if there is any abnormality or peculiar smell in the indicator light or overheating of the charger case, stop charging immediately and repair or replace the charger.
- It is prohibited to disassemble or replace the components of the charger by yourself.
- The charger shall be replaced to match the battery model.

## Charging environment

- If the battery is placed on the vehicle, the work of the intelligent system and alarm system of the vehicle will consume the electric quantity of the battery in real time. After the vehicle is placed for a period of time, the meter will display the decrease of the electric quantity, which is a normal phenomenon. In general, if the vehicle is parked for 8 hours, the electric quantity of the battery will be consumed by about 5%, which is a normal phenomenon.
- Please store the battery at an ambient temperature of 0°C - 25°C. Please do not store the battery in an environment higher than 40°C, otherwise the battery will experience irreversible capacity attenuation.
- For vehicles that are not in use for a long time (such as in winter, summer or other special circumstances), the battery shall be taken out for separate storage and maintained and charged regularly, or the battery may be completely depleted and irreversibly damaged. Battery failure caused by such problems will not be included in the range of "three guarantees".
- For the battery, the most appropriate storage capacity is 50%. If it is lower than 10% or higher than 90%, long-term storage will lead to irreversible capacity attenuation of the battery.
- For the lithium battery, the technical standards of the electric quantity consumption protection mode for safe storage are as follows:
  - (1) If it is not used for a long time and stored on the vehicle (without unplugging the battery), the safety period shall be at most one month, otherwise the battery feed may occur and the problem cannot be repaired.
  - (2) If it is not used for a long time, the electricity quantity shall not be less than 50%, and it shall be stored separately or placed on the vehicle (disconnect the plug). The maximum safety period is 3 months. Otherwise, battery feeding, which cannot be repaired may occur.
- Avoid storing the battery in a place where there is a risk of falling, which may cause uncontrollable damage to the battery and may lead to leakage, heating, smoking, fire or explosion of the battery.

The battery undervoltage caused by the above-mentioned improper behaviors shall not be covered by the warranty.

## Precautions for battery use

- Please make sure that the battery had been exhausted when you use the battery for the first time, then charge it and repeat this process for two or three times to ensure that the actual capacity of the battery is consistent with the displayed capacity on the dashboard.
- Ensure that the battery power is not less than 20% and charge it in time, which can prolong the service life of the battery.
- In daily life, it is recommended to use a mid-range speed. Start slowly and operate the throttle handle to accelerate gradually, which also can prolong the battery life.
- As the number of times the battery is used increases, there will be deviation between the actual capacity of the battery and the displayed capacity on the dashboard. Please fully discharge and recharge the battery regularly (no more than 3 months). The internal battery cell and intelligent system can automatically calibrate the electricity quantity to improve your experience.
- It is recommended to check the power plug of the battery every two months for carbon deposition and oxidation blackening on the contact reed.

△The battery shall not be placed in the rain or even be soaked in the water. The whole battery compartment shall not be soaked in the water, otherwise water will enter the battery, causing internal short circuit and permanent failure of the battery. In the above-mentioned case, it is strictly prohibited to charge the whole vehicle or battery again, otherwise it will cause fire, combustion and explosion. Please hand over the battery to the designated network for maintenance immediately

## 5 Troubleshooting

Problem phenomenon	Reason	Treatment method
Turn on the power supply, but the whole vehicle has no power output	No power supply to the vehicle	1. Check whether the power plug is connected properly 2. Battery undervoltage. Please charge it.
Turn on the power supply and turn the speed regulating handle, and the motor does not start up.	1. The vehicle is braked 2. The vehicle is parked 3. The side brace is not retracted. 4. Start switch failure	1. Check whether the brake handle is in the braking state 2. Refer to that "start-up operation" section of the instruction manual 3. Pack up the side brace 4. Contact the after-sales service and check the start switch
Insufficient endurance mileage	1. Low battery 2. Insufficient tire pressure 3. Frequent brake and start or overloading 4. Battery aging or normal electric quantity decay 5. Low ambient temperature or reduced battery capacity	1. Check the charger for damage 2. Check the tire pressure before use 3. Develop good driving habits 4. Replace the battery 5. It is normal
The battery cannot be charged	1. The charger plug is not connected properly 2. The battery temperature is too low 3. The battery temperature is too high	1. Check whether the plug connection is loose 2. Wait for the battery to recover to the normal temperature 3. Wait for the battery to recover to the normal temperature

## Judgment of common faults and troubleshooting of lithium battery

Problem phenomenon	Reason	Treatment method
The battery has no electricity and light bar is not on after pressing the button	The battery runs out	Charge
After turning on the power, light bars all flash	The battery runs out or the battery failed	Charge it and contact the branches for detection
When driving at low power, such as 5%, the power is off and the screen turns black.	The battery runs out, which is normal	Charge it
After parking, power on within a short period of time, such as 1 to 2 hours, the displayed capacity increases or decreases dramatically	Internal calibration calculation of battery cell electric quantity is a supplement to inaccurate dynamic electric quantity for riding.	Normal service
When driving with normal electric quantity, such as 15%, the power is off and the screen turns black	It is normal to see the battery runs out Long-term use of batteries leads to the inaccurate calculation of capacity	Carry out fully charging and discharging
After parking, power on within a short period of time, such as 1 to 2 hours, the displayed capacity increases or decreases dramatically	It is normal to see the battery runs out Long-term use of batteries leads to the inaccurate calculation of capacity	Normal service
After parking, power on within a long period of time. For example, the displayed capacity of the dashboard decreases dramatically overnight	The alarm consumes electricity about 5% for 8 hours	Normal use.

## 6 Precautions for battery extraction

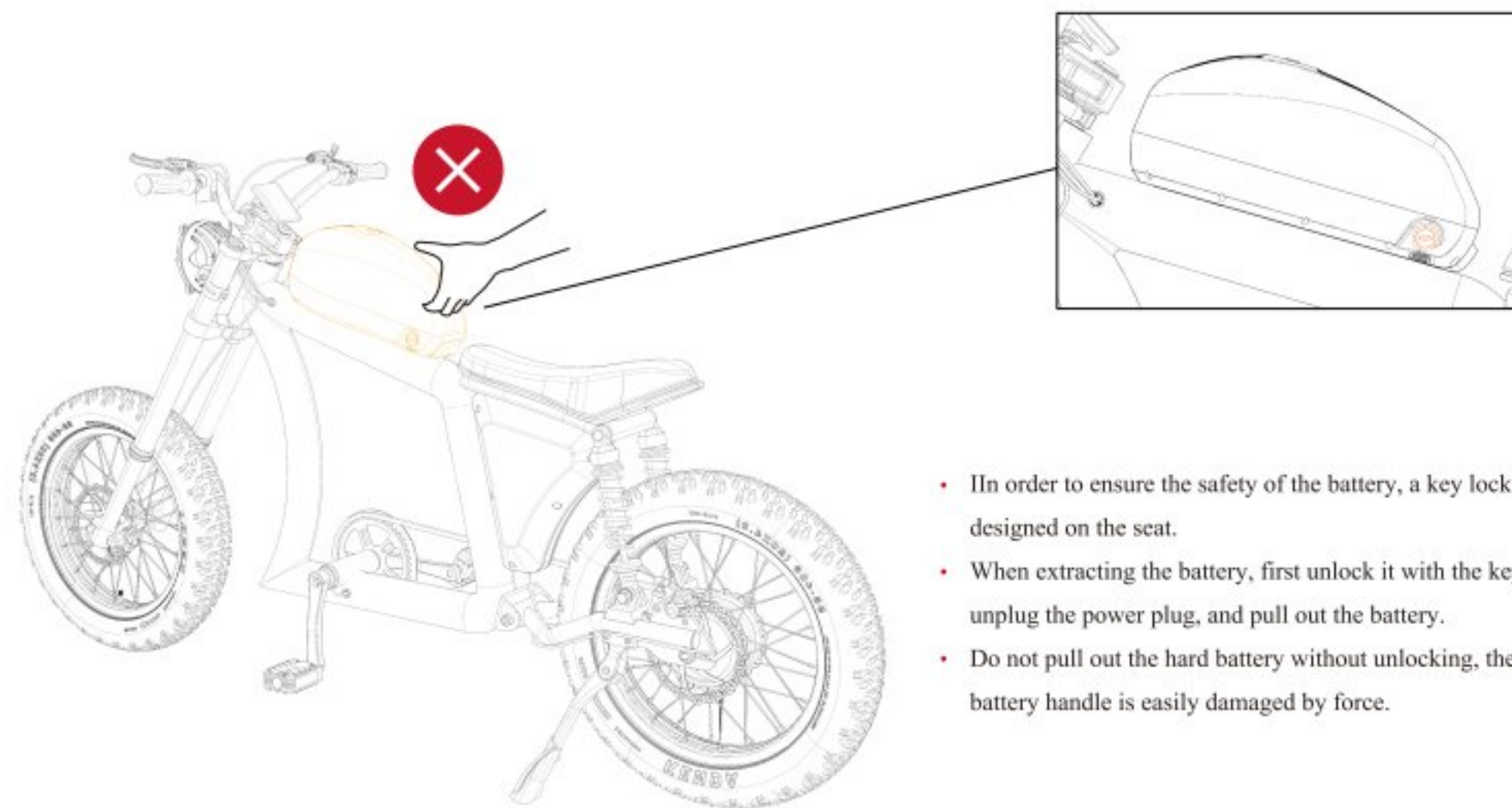

- In order to ensure the safety of the battery, a key lock is designed on the seat.
- When extracting the battery, first unlock it with the key, unplug the power plug, and pull out the battery.
- Do not pull out the hard battery without unlocking, the battery handle is easily damaged by force.

## 7 Maintenance and Servicing

### Inspection items of regular maintenance

Regular maintenance can extend the value of vehicles from products to daily use.

**Adjustment in run-in period:** After using the new purchased vehicle for one month (distance: 500km), conduct adjustment in run-in period so that the car can be integrated into your life in the most perfect posture.

**First maintenance:** After using the new purchased vehicle for four months (distance: 1,500km), carry out the first maintenance for your vehicle that has been with you for several months.

**Second maintenance:** After using the new purchased vehicle for ten months (distance: 3,000km), carry out the second maintenance to prolong the service life of your vehicle.

All maintenance items are shown in the following table. The actual maintenance items can be flexibly selected according to the vehicle type, riding mileage and time:

Description	Inspection item
Structural member	Nut fastener of the whole vehicle
	Bolt fastener of the whole vehicle
	Tire inspection
Brake system	brake fluid inspection
	Abnormal sound inspection when braking
	Braking effect inspection
	Brake disc inspection
Electrical components	Inspection of power lock and alarm
	Light inspection
	Inspection of the dashboard
	Combined switch inspection
Electrical components	Voltage inspection of the charger
	Inspection of the function of APP
Suspension + steering system	Front and rear shock absorption inspection
	Steering inspection of the handlebars
	Front wheel inspection
Battery	Appearance inspection of battery box
	Waterproofness inspection
	Battery detection
	Charging test
Vehicle riding	Vehicle operation inspection
	Inspection of abnormal sound of whole vehicle
	Parking inspection

## Vehicle cleaning

Please scrub the scooter with tap water and a neutral detergent. After that, wipe it clean with a soft cloth.

- A It is prohibited to directly flush both sides and rear interior of the battery box with a high-pressure water gun. Do not flush directly the side cover above the rear wheel where the charger and controller are located to avoid water inflow and damage.

### Scooter storage method

- Please store the scooter in a flat, stable, well-ventilated and dry position.
- Avoid the exposure of scooter to the sun and rain as much as possible, which can reduce the damage or aging of parts.
- For long-term storage, please refer to Instructions for Battery Use and Maintenance for battery maintenance.
- When reusing after long-term storage, please fully charge the battery.
- Please confirm there is no abnormality in all parts before riding.

## 8 Basic parameters

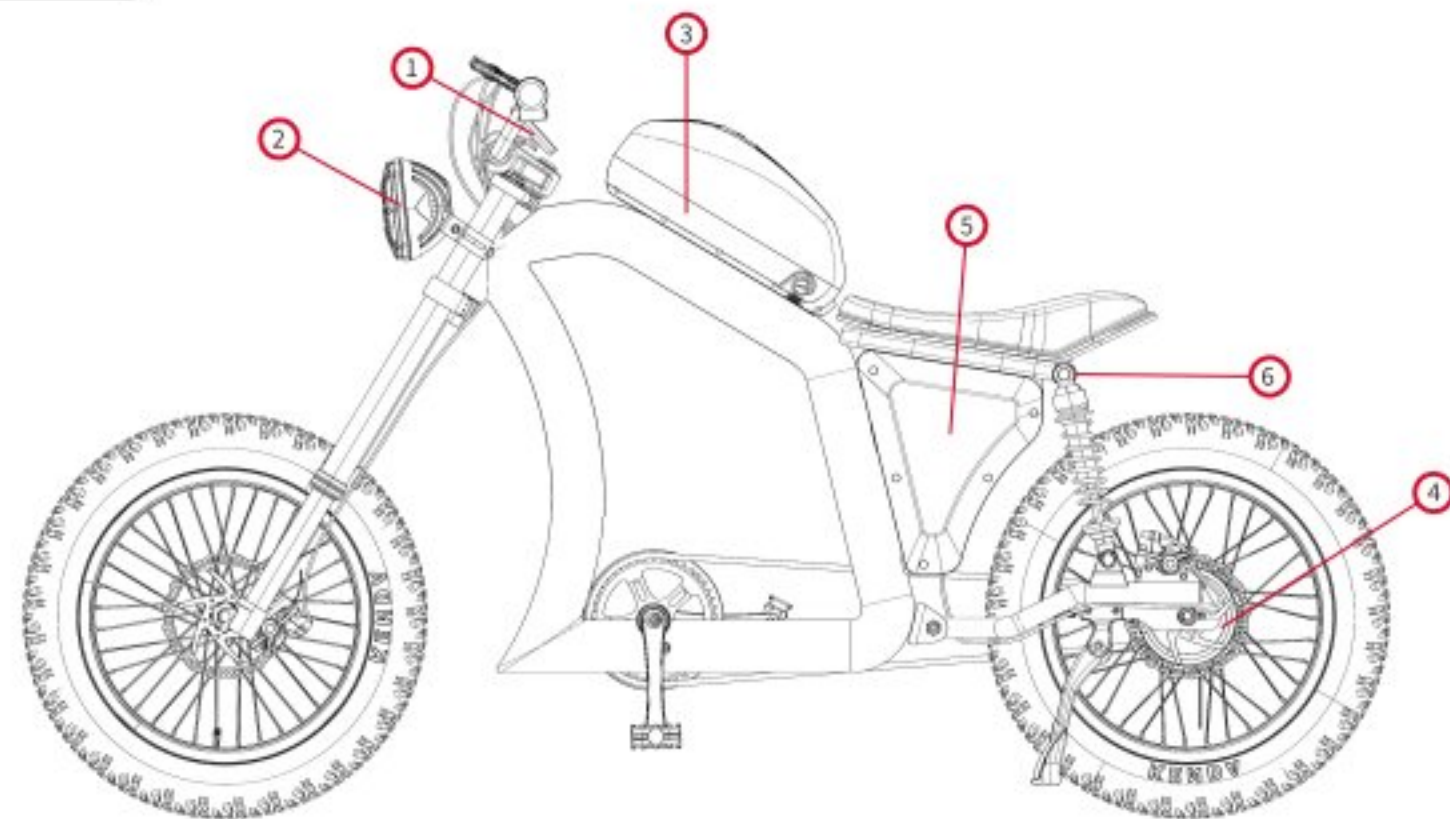

No.	Part Name	No.	Part Name
1	Speedometer	5	Motor control unit
2	Head lamp(driving/passing beam) front position lamp Daytime running lamp	6	Rear Light
3	Pull-out battery		
4	Motor		

Project	Parameters
Model	FT-02
Overall dimensions	2030*745*1080mm
Frame Material	Aluminum alloy frame or Seamless pipe frame
G.W./N.W	52.5kg/43kg
High speed	25km/h 40km/h 60km/h
Mileage	13.5Ah-electric mode 27km & power save mode 45km 22.5Ah-electric mode 45km & power save mode 70km
Tire size	20 inch city road tire
The capacity of power storage batteries	13.5AH-31.5AH
Braking mode	Front and rear hydraulic brake
Motor power	250W/750W/1500W
Packing size	whole vehicle packing-1750*280*860mm remove front shock absorption packing-1580*375*780mm
Gradeability	15°
Acceleration mode	Handleber Acceleration
Charging time	4-6hours



**Warranty card**

User name \_\_\_\_\_ Address \_\_\_\_\_ Postcode \_\_\_\_\_  
Engine No. \_\_\_\_\_ VIN \_\_\_\_\_ Date of purchase \_\_\_\_\_

**Maintenance record sheet**

**Distribution unit (seal):**

Date	Repair and replacement	Repairman	Comments

Note: This warranty card is invalid without the seal of the distributor.

